

In this issue

- Editorial [P.1](#)
- The Local Positioning System [P.4](#)
- Strain, Temperature and Acceleration Sensors [P.3](#)
- Component Testing - Test Results and Analysis [P.4](#)
- The Structural Assessment Module [P.5](#)
- Damage Methodology for Multi-View Oblique Airborne Imagery [P.6](#)
- News and Events [P.8](#)
- Consortium [P.9](#)

Editorial

Welcome to the 3rd newsletter of the RECONASS project.

RECONASS is a European 7th Framework project funded under the SEC programme (grant agreement no. 312718).

The main objectives of the project are (a) to provide a monitoring system for critical buildings that will provide a near real time reliable and continuously updated assessment of the structural condition of the monitored building after a disaster, (b) in case of spatially extended events, e.g., a strong earthquake, to use the above assessment of the monitored facilities for the speedy calibration of satellite and oblique aerial photography of the damaged area and (c) to provide a post-crisis needs assessment tool in regards to construction damage and related needs that will be based on input from (a) and (b) above.

The project officially launched its activities in December 2013. Since then the partners have developed (a) a first prototype of the monitoring system that consists of local positioning tags to determine the position of selected points of the structural system before and after a catastrophe and thus determine the structure that has emerged from the disaster, strain sensors attached to the columns at the ground level to determine the distribution of loads and accelerometers to assess the structural condition under vibrations in the case of seismic loading, (b) a methodology and coding for structural assessment and (c) a damage methodology for multi-view oblique airborne imagery. Last but not least, the partners have successfully performed two separate series of component tests on two structures of different complexity mainly to support the design of the large RECONASS pilot in which the integrated system will be demonstrated.

In this issue you will find a description of the first prototype of the local positioning system, the strain, acceleration and temperature sensors, the module for structural assessment, the damage methodology for multi-view oblique airborne imagery and the results of the first component tests.

Angelos Amditis

Project Coordinator



This project has received funding from the European Union's Seventh Framework Programme for research, technological development and demonstration under grant agreement no [312718]

Project facts

DURATION

42 months

TOTAL COST

5,48 million euro

REQUESTED EU CONTRIBUTION

4,26 million euro

The Local Positioning Prototype

Since the last newsletter, the designed application-specific integrated circuits (ASICs) for the RECONASS LPS were returned from manufacturing and tested in the frame of a small-scale prototype with 6 nodes.

The RECONASS system ASIC implements a dual band radio frequency front end for frequency modulated continuous wave (FMCW) radar systems in the 2.4 and 5.8 GHz ISM bands (Fig.1).

To achieve larger ranges with the system and to penetrate obstacles with the radar signals while keeping a good signal-to-noise ratio, an external power amplifier is connected to the system chip. It is also a custom design, which is able to handle both targeted ISM bands, thereby saving external components and reducing system cost (Fig.2).

Several measurements were carried out in different test scenarios to benchmark the performance of the prototype. The final system measurements were evaluated in terms of their precision and accuracy under different conditions. One ranging scenario with two nodes and two positioning scenarios were set up, one outdoors and one indoors, using three nodes and a mobile node, which is used to benchmark the measurement of 2D coordinates.

Table 1 summarizes the performance of the LPS

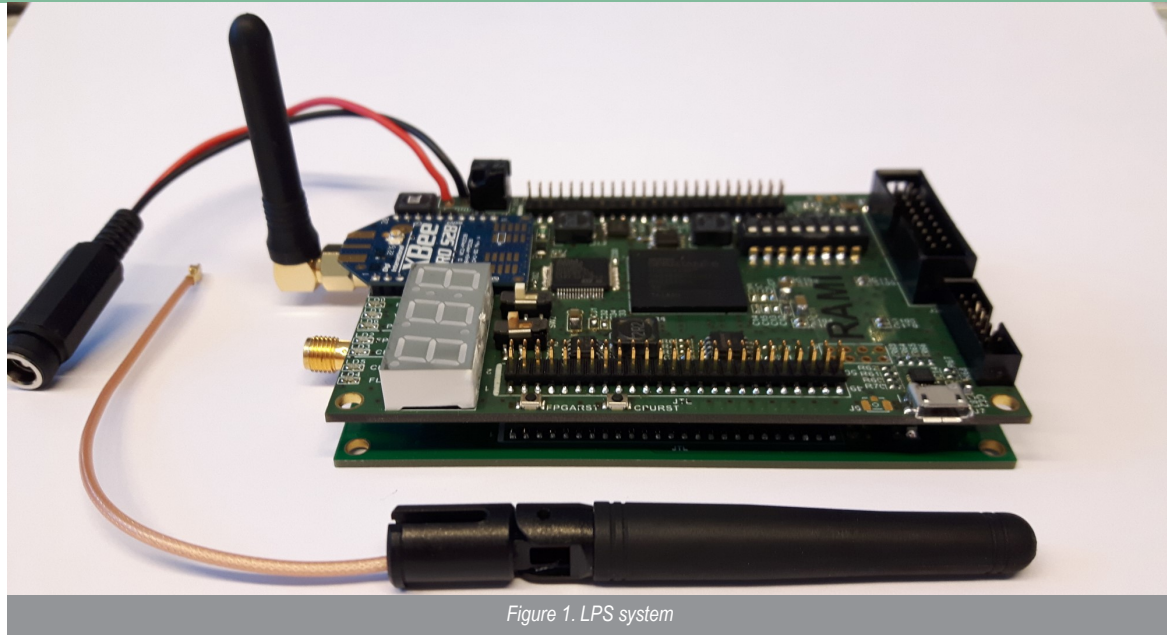

Figure 1. LPS system

prototype. In the outdoor scenario with rod antennas and the indoor scenario with directive antennas, precision is in the order of 1.5cm. This value is close to the theoretical boundary, since signal reflections are almost eliminated because of the scenario or the used antenna. Positioning precision is naturally worse than ranging precision, because the result incorporates several independent stations. Absolute accuracy for the outdoor scenario with low multipath propagation is around 30cm, while it is almost double in a reflective indoor scenario. However, for the use in the RECONASS project, where displacement of the nodes has to be determined, precision is the important parameter, which stays below 11cm in the challenging indoor scenario.

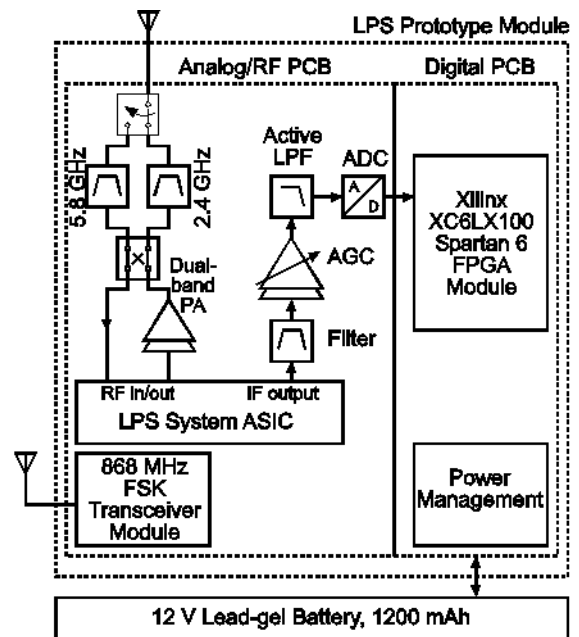

Figure 2. LPS prototype module block diagram

	Accuracy/cm	Precision/cm
Outdoor Ranging	< 16	< 1.45
Indoor Ranging	< 31	< 1.15
Outdoor Positioning	< 30	< 11
Indoor Positioning	< 65	< 9

Table 1. Measured system accuracy and precision in different scenarios

Strain Sensors

The strain gauges selected for RECONASS are the “1-LY41-20/120” & “K-LY4-1-11-120-3-1” coming from the HBM Manufacturer. These are linear gauges that come with a Constantan measuring foil and polyamide carrier. Their temperature response matches the response of steel with and come with integrated soldering tabs. All gauges tested had a resistance of 120 ohms. The estimated power to be dissipated for 5 and 10V excitation is about 52 and 208mW respectively in each arm of a Wheatstone bridge. Considering the electrical noise environment and an analog-to-digital (A-D) conversion processing requirement, an excitation voltage of 10V was considered ideal. The strain-gauges are operated in a Bridge Completion Module (Wheatstone bridge) circuit. The bridge is initially balanced with an adjustment potentiometer as shown in Fig. 3. A water proof barrier using a compound, such as M-COAT JA, is built after initial testing of gauges. In the present testing, the strain-gauges are bonded to steel-rebars and a force is applied. The strain is found indirectly, by measuring the change in voltage due to variation in resistance (Fig 4). The same load was applied a number of times and the average strain was noted.

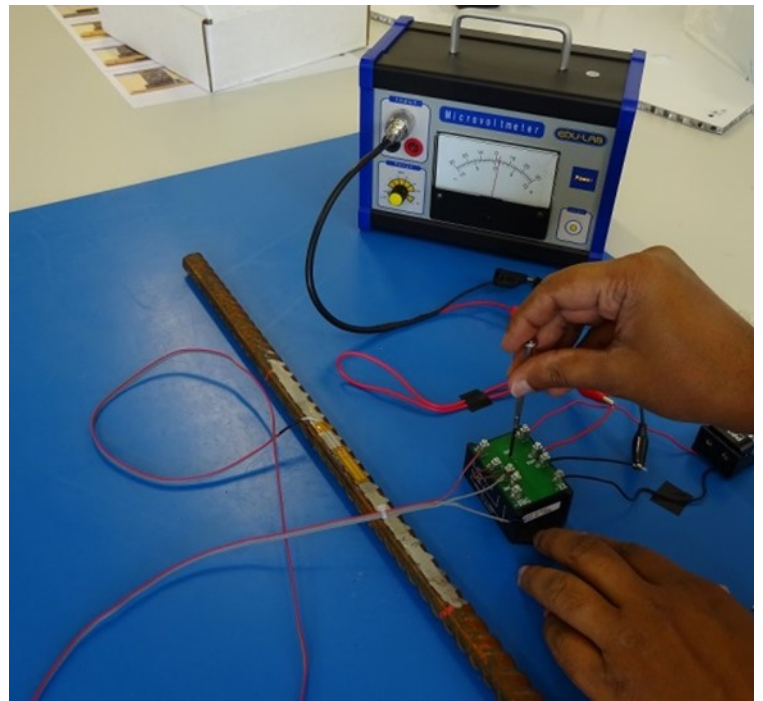

Figure 3. Bridge Balancing with Adjustment Potentiometer

Temperature Sensors

Infrared thermometers have the ability to measure object temperatures contactless. The product “CSmi-SF15-C6/3 Miniature Pyrometer” is to be used in the RECONASS project. The spectral response of this product is 8-14 μ m and produces an analogue voltage proportional to the detected temperature. This Pyrometer provides analogue output in ranges 0-5V or 0-10V depending on user request. It is capable of measuring temperatures between -40 and 1030 $^{\circ}$ C; A set of checks were carried-out to test the accuracy of the measured temperature. The analogue output voltage for corresponding temperature was measured. The output voltage was converted to temperature and compared with a thermocouple result. A K-type thermocouple was also used to independently measure the temperature. Pyrometer result was compared with thermocouple based measurement. Both results were very close, within 2% of each other. CSmi-SF15-C6/3 Miniature Pyrometer satisfies the requirements of structural engineers for the majority of cases. These Pyrometers seamlessly integrate with data-acquisition systems. Thus, real-time and continuously updated assessment of temperature changes can be monitored for facilities. Simple tests gave useful guidance on calibrating these sensors for the future deployment in pilot and large-scale testing.



Figure 4. Rebar at a Strain of 2040 μ ϵ

AC-43 Triaxial Accelerometer

The AC-43 is a triaxial force balance accelerometer designed to be used to monitor natural or manmade vibrations created by earthquakes, construction, blasting, traffic etc.

The accelerometer is based on the modern MEMS (Micro Electro-Mechanical Systems) technology, and consists of MEMS cells assembled in an innovative way that optimizes their performances. A state of the art proprietary circuit design yields a cost effective and reliable accelerometer. MEMS cells are linear accelerometer elements which measure the capacitance variation in response to any movement or acceleration. They are micro sized structures constructed as a second order mechanical system, composed by a mass, a spring and a damper (Fig.5).

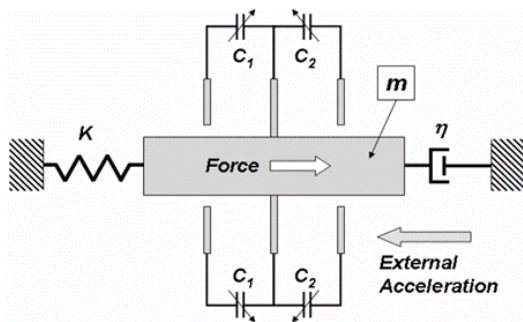

Figure 5. Schematic mechanical system of a capacitive accelerometer

When an external acceleration acts on the system, the mass moves in the opposite direction of the acceleration. The displacement is then sensed by a capacitive system. It is formed by a number of electrodes that are connected with the mass and therefore are free to move and others that are clamped to the substrate. The displacement of the mass causes a change in the capacitance measured by the electrostatic system. A factory trimmed interface chip converts the capacitance variations into a signal that is proportional to the motion. Thus from the direct measure of this change it is possible to compute the value of the external acceleration.

The mechanical structure of the cells consists of micro machined silicon material which yields a sensor with low noise and distortion, as well as with high bandwidth, dynamic range, stability and robustness.

The accelerometer can measure from DC up to 200 Hz and from few hundred micro-g's up to 5 g, while being able to withstand shock impacts up to 3'000 g over 0.5 ms and having an operating temperature range from -40 to +85 °C. With the help of a test line the accelerometer can be completely tested assuring proper operation. The accelerometer is typically housed in a sealed cast aluminium housing with dimensions of 195 x 112 x 96 mm. The housing also incorporates a single bolt mount with three levelling screws.

COMPONENT TESTING

Test Results and Analysis

During the spring of 2015, component tests have been performed within the RECONASS project. At the end of the RECONASS project in 2016, a final test of the system will be performed in Älvdalen, Sweden. In order to test structural components (i.e. concrete structure and material) for blast impact, and to get results which would make it possible, through simulations, to make estimates and calculations for the final test, these component tests were performed. An additional purpose of the tests was to test the sensors developed in RECONASS for blast resistance.

In the tests, half scaled reinforced concrete structures, both single slabs and more complex multi-node frames, were tested against blast load. In all the tests a large amount of different gauges monitored the blast load and the behaviour of the elements with high time resolution.

The design of the tests, such as the amount of explosives and distances, was done with simulations, which also gave useful guidance in choosing gauges for the test, and provided the sensor developers with important information about the durability of the equipment against blast impact. The non-linear finite element (FE) simulations were performed to determine the blast loads and the structural displacements prior to the model scale component testing. The FE simulations predicted the response of the accelerometers used in the model scale test with a good agreement, both regarding deformations and failure modes.

The results from the model scale reinforced concrete component testing, and the presented FE analyses, provide data for design of the setup for the full scale structural testing planned as the final test of the RECONASS system.



Figure 6. Left: One of the test structures with instrumentation inside. Right: One of the explosives test with the test structure to the left and the blast to the right.

The Structural Assessment Module

A 'Structural Assessment Module', based on monitoring data from strain, acceleration, displacement and temperature sensors installed in reinforced concrete building structures, in combination with the use of a commercially available non-structural analysis software, is developed, resulting in the near real time estimation of the structural condition for the structural members, as well as the stability of the whole structure due to the following events.

- Normal operating conditions
- Earthquake
- Explosion
- Fire

To directly assess the axial force and the bending moments in a cross-section, strain sensors are required at the three corners of the cross-section at the extremes of each structural member. Thus, a total of 6 sensors are required for each member, such as beam, column and shear wall. Therefore, for a structural system consisting of 'n' linear members, the required no. of sensors will be 8n. As an example, for the direct assessment of the internal forces in the members of a 6-story building with plan dimensions of 15x15 m², to which correspond about 16 columns and 24 beams per story, the total no. of members being $n=6(16+24)=240$,

the required no. of sensors will be $8 \times 240 = 1920$.

The no. of required sensors has been dramatically reduced in this work because instead of aiming at a direct assessment of the internal forces in each member; some critical global parameters of the overall stress condition are being sought. Then, under operating conditions, the internal forces in each structural member as well as their structural adequacy and the differential settlement between foundations have been assessed through a finite element programme that accepts as input the measured values of the above critical parameters. In this case strain sensors are only placed at the columns' bottom cross-section of the ground floor. In the case of the 16 columns of the 6 story building in the previous example, the no. of the required strain sensors is reduced to $6 \times 4 = 64$ sensors.

A novel energy-based theory of seismic failure for reinforced concrete members has been developed involving the plastic hinges developed at their end cross sections. In the previous version of this theory failure ensues at the locations of maximum bending moments where there is no shear. In this work, the above theory has been refined and extended to include shear.

The module consists of the following parts:

Part 1. Long term estimation of the variation with time of the actual loads applied on the structure and the resulting structural response.

The module will receive in specific time intervals the inputs from the strain sensors installed on three reinforcing bars at the corners of the bottom cross sections of the columns in the ground floor and will calculate the axial forces and bending moments developed. Furthermore it will calculate possible differential settlements and the live loads applied at the time of the measurement. By using a commercially available non-linear analysis program it will estimate the safety factors at critical cross sections of the structural members corresponding to the calculated loads and differential settlements.

Part 2. Short term estimation of the structural integrity due to the oscillations stimulated from earthquake.

In a first step the sequences of horizontal displacements at two extreme points of the floors and the foundation will be calculated after double integration of the inputs from the accelerometers. In a second step these displacements will be introduced as imposed displacements to the commercially available non-linear analysis program on the structural model of the building. From the results of the analysis will be estimated (a) the local damage index at the

critical cross sections of the structural members based on an energy based damage criterion, and (b) the overall instability index of the whole structure.

Part 3. Short term estimation of the structural integrity due to the oscillations stimulated from the blast after explosion.

The reduced resistance of members heavily damaged from the blast is introduced in the structural model and the analysis is executed as in the part 2.

Part 4. Thermal effects on the strength of the structural members.

A fire usually follows a blast implying the development of high temperatures varying with the position in the building and with time. The module will receive the inputs from the temperature sensors distributed over the whole structure. The temperatures at the position of the critical cross sections of the structural members and their variation with time will result from a space interpolation module. The rate of the heat quantity transferred to the structural members from the fire following the blast will be estimated and so will the reduced strength of concrete, steel and the critical cross sections. For this purpose the values of thermal conductivity, specific heat and thickness of concrete covering the reinforcing steel bars will be added to the properties of structural mate-

rials. The module calculating the internal forces will be modified by the introduction of the respective laws of variation of strength and deformability properties for the different finite elements constituting the mesh over the area of each cross section with respect to their depth from the free surface of the member.

Part 1 is needed to provide input to the other Parts (on earthquake, explosion, and fire) on the structural condition at the time of the disaster. Part 1 depends on strain sensors embedded during the erection. In existing buildings where the installation of strain sensors is not possible, Part 1 can be eliminated and the structural assessment for the normal operating loads can result from the analysis of the structure for the known values of the dead and the quasi-permanent loads and the estimated value of the actual live load during the normal operation. This will still permit the evaluation of earthquake or fire structural response in existing buildings (accelerometers and temperature sensors do not need to be embedded and can be easily installed in existing buildings). This assessment can be used to direct structural engineers to locations of physical damage, even if they are concealed behind architectural finishes.

Damage Methodology for Multi-View Oblique Airborne Imagery

Methodology for building level damage detection using airborne oblique images

Remote sensing-based structural damage assessment is one of the sub-systems of the RECONASS system. As part of this sub-system, methods have been developed for an automatic building delineation and identification of various damages (described below) to the delineated building, using the images captured by an unmanned aerial vehicle, and the 3D point cloud derived from them. A brief description of the developed methods is provided below.

a) Automatic building delineation

The individual buildings in the scene are delineated based on identifying spatially connected roof segments. As an initial step, the 3D point cloud is segmented into disjointed planar segments, using the plane-based segmentation. The non-vertical segments above a certain height from the ground are detected as roof segments. The spatially connected roof segments are merged and delineated as a single building (Fig. 7).

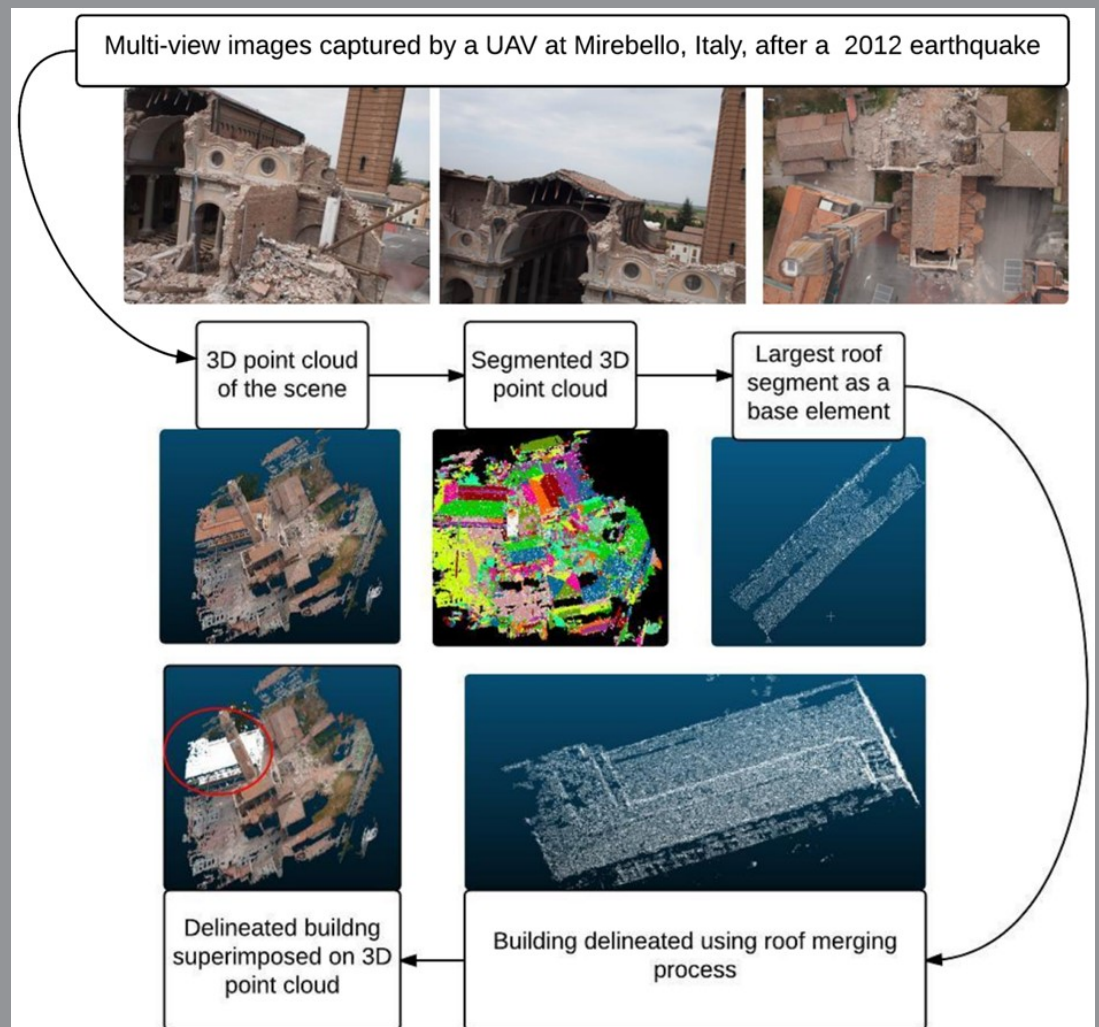

Figure 7. Example of Building Delineation Process

b) Method for debris and spalling detection

The areas of debris and spalling look rough and flaky in nature, and possess uneven radiometric distribution pattern (e.g., histogram of gradient orientation) compared to non-damaged areas in an image (Fig. 8).

A supervised learning approach is adopted to develop a model for automatic identification of image regions corresponding to debris and spalling based on the radiometric pattern. The training set comprising of the image patches of damaged and non-damaged regions is provided

to the learning model to learn the underlying difference between the damaged and non-damaged regions in terms of image features. The trained model is then used to classify the new images. For example see Fig. 9 where the damaged areas in the image are identified using the learning model developed based on support vector machine (SVM) (learning algorithm) and Gabor wavelets (image feature). Images x-y illustrate the method with images acquired following an earthquake in 2012 close to the city of Mirabello.

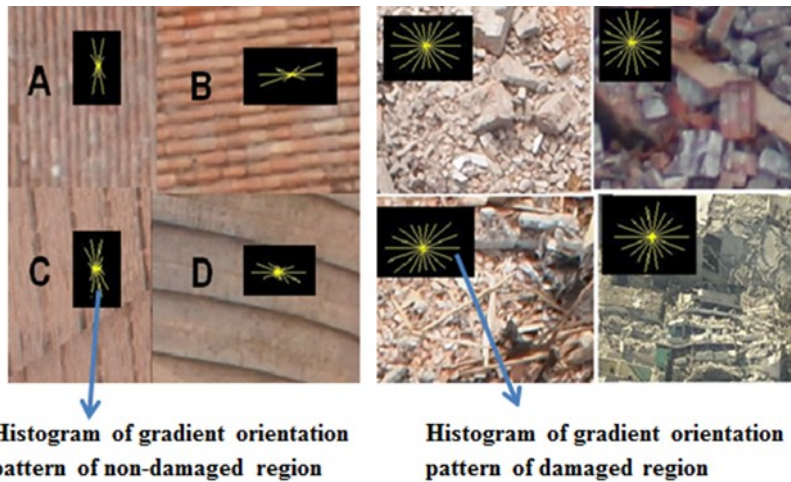

Figure 8 Radiometric pattern of non-damaged and damaged image regions



Figure 9. UAV image taken after the 2012 Mirabello earthquake (left); damaged regions mapped by our method in red mask (right)

Follow-up RECONASS

The end user group is invited to follow-up the RECONASS process during the project's lifetime via the RECONASS homepage (www.reconass.eu) as well as via twitter and LinkedIn and to contribute within all in all three RECONASS end-user workshops.



www.reconass.eu



[#Reconass](https://twitter.com/Reconass)



[RECONASS group](#)

c) Detection of structural gaps caused by damage

Structural openings/gaps that appear in a 3D point cloud are highly complex, and for several reasons they can be normal and desired features (e.g., architectural elements), but they can also indicate damage. However, due to the 3D information generation process, gaps can also be created in case of partial building occlusion (e.g., by vegetation) or image matching problems.

Automatic methods have been developed to identify and characterise a gap, leading to a reliable determination of openings due to structural damage. The 3D point cloud space is split into uniform 3D cubes (voxels) and the cubes with no 3D points are identified as gaps (Fig 10). The gaps with debris or spalling around them are classified as gaps due to structural damage (c.f. fig z), since any deformation in the concrete surface creates a sign of spalling or debris around the deformed region.

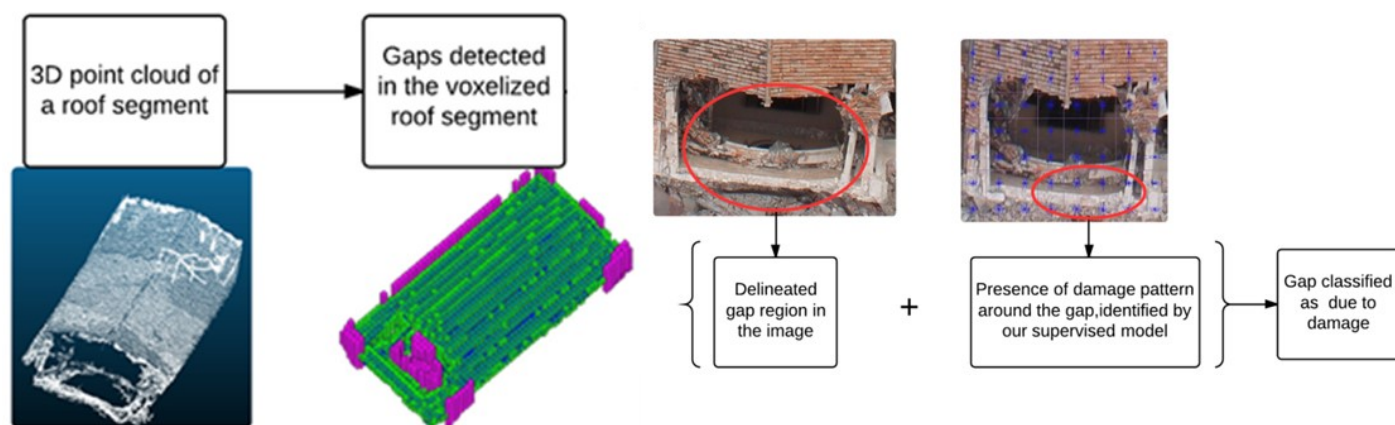

Figure 10. Detection of Structural Gaps

News and Events from May 2014 to November 2015

Scientific Presentations/Publications

B. Al-Qudsi, M. El-Shennawy, Y. Wu, N. Joram and F. Ellinger, 'A Hybrid TDoA/RSSI Model for Mitigating NLOS Based Indoor Positioning Systems,' IEEE PRIME 2015, 29th June-2nd July, 2015, Glasgow, UK.

N. Joram, J. Wagner, E. Sobotta and F. Ellinger, 'Fully Integrated Wideband Sub-10GHz Radio Frequency Front End with Active Matching,' IEEE PRIME 2015, 29th June-2nd July, 2015, Glasgow, UK.

J. Wagner, N. Joram, B. Al-Qudsi and F. Ellinger, 'Designing Positioning Systems for Public Protection and Disaster Relief Applications,' European Conference on Networks and Communications EuCNC 2015, 29th June-2nd July, 2015, Paris, France.

E. Sdongos, 'RECONASS: Reconstructin and REcovery Planning: Rapid and Continuously Updated CONstruction Damage and Related Needs ASSessment, EUROCONCIP, Oct. 20, 2015, Rome, Italy.

M. El-Shennawy, M. Eissa, M. Schulz, N. Joram and F. Ellinger, 'A Scalable Synchronous Reload Technique for Wide Division Range Multi Modulus Dividers,' IEEE-ICECS 2015, Dec. 6-9, Cairo, Egypt (It has been selected among the top 10 papers and is competing for the paper award)

Consortium

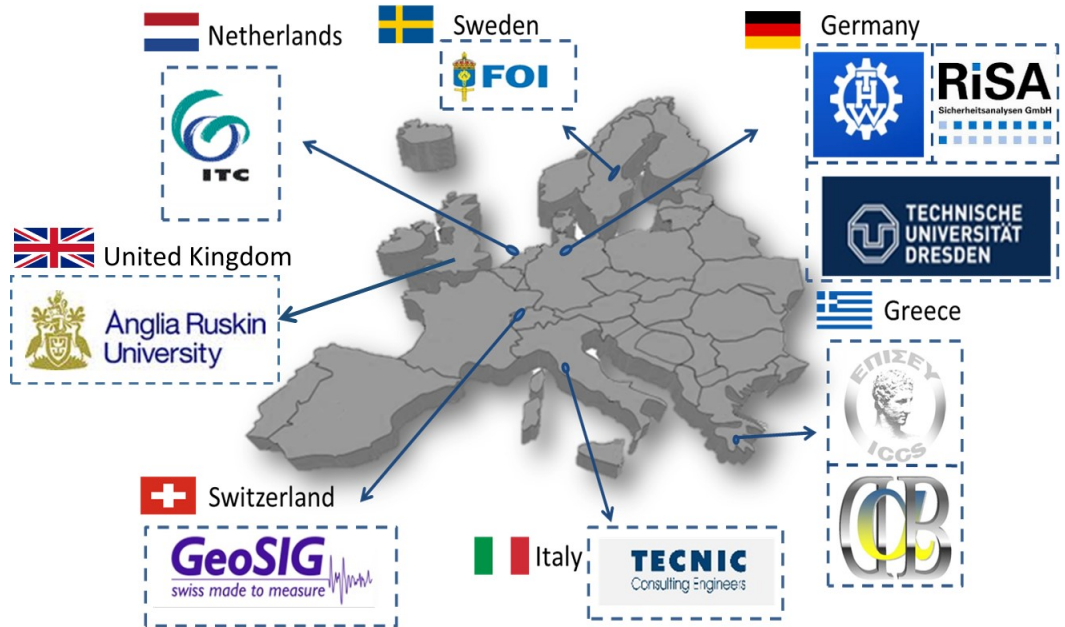

Contact Us

Project Coordinator:
Dr. Angelos Amditis
(a.amditis@iccs.gr)

Dissemination Manager:
Stephanos Camarinopoulos
(s.camarinopoulos@risa.de)



Visit us on the web site at
www.reconass.eu or www.reconass.com



Follow us on [Twitter](#)



Join us or [RECONASS LinkedIn group](#)